

Product information

Drummotors

**TM 113B25**



*Van der Graaf*  
Power Transmission Equipment

[www.vandergraafpte.nl](http://www.vandergraafpte.nl)

# The TM 113's playground







# TM 113B25

## A wide range of applications

Van der Graaf has achieved a prominent position on both the domestic and international market with its "GV" Drummotors. The "GV" Drummotor has found success in a wide range of applications including the following: automotive, X-ray, construction, postal, courier, mining, aggregate, airline baggage, package flow, tyre manufacturing, fish processing, poultry processing, meat processing, agriculture, fruit and vegetable, farming, forestry, baking, dairy and many more.

4	Introduction
5	Selection table
6	Dimensions Drummotor mild steel
	Dimensions Taildrum mild steel
7	Dimensions Drummotor stainless steel
	Dimensions Taildrum stainless steel
8	Dimensions bracket / Cable exit
9	Cross sectional / parts description
12	Options
15	Product range
16	Contact us



## Selection table

TYPE TM 113B25	Power kW	Beltspeed m/s at 50 Hz									Min. L mm Design B	Full load curr. 400 V - 50 Hz I = ... A	Weight kg L=350	
		Beltpull N												
275 Z	0,55	4,40 120	4,00 130	3,20 165	2,80 185	2,50 210	2,20 240	1,90 270			310	1,20	16	
205 Z	0,37	4,40 80	4,00 90	3,20 110	2,80 125	2,50 140					310	0,80	16	
405 Z 405 PL2	0,37	2,20 160 0,85 400	2,00 175 0,70 485	1,60 220 0,65 525	1,40 250 0,55 620	1,25 320 0,50 680	1,10 370 0,45 755	0,95 470 0,40 850	0,75 585 0,34 1000	0,60 1150	360	1,35	16	
234 Z	0,25	4,40 55	4,00 60	3,20 75	2,80 85	2,50 95					260	0,65	16	
434 Z 434 PL2	0,25	2,20 110 0,85 270	2,00 120 0,75 305	1,60 150 0,70 330	1,40 170 0,65 355	1,25 190 0,55 420	1,10 215 0,50 460	0,95 250 0,45 510	0,40 575	0,34 675	0,27 850	310	0,70	16
634 Z 634 PL2	0,25	1,00 240 0,29 795	0,90 265 0,25 920	0,80 295 0,21 1095	0,70 340 0,17 1150	0,60 395	0,50 475	0,40 595			360	0,95	16	
425 Z 425 PL2 425 PL3	0,18	1,60 105 0,85 195 0,20 790	1,40 120 0,75 220 0,18 880	1,25 135 0,70 235 0,16 990	1,10 155 0,65 255 0,13 1150	0,95 180 0,55 300 0,11 1150	0,50 330	0,45 370	0,40 415	0,34 485	0,27 615	275 275 310	0,55	16
625 Z 625 PL2	0,18	0,90 190 0,25 660	0,80 214 0,21 790	0,70 244 0,17 975	0,60 285						310	0,65	16	
416 Z 416 PL2 416 PL3	0,12	1,10 105 0,85 130 0,18 585	0,95 120 0,75 145 0,11 960	0,70 160 0,07 1150	0,65 170	0,55 200	0,50 220	0,45 245	0,40 275	0,34 325	0,27 410	260 260 310	0,40	16
816 PL2 816 PL3	0,12	0,31 355 0,10 1055	0,22 500 0,08 1150	0,20 550	0,16 690	0,13 850					310 360	0,65	16	
811 PL2 811 PL3	0,08	0,31 235 0,10 705	0,26 285 0,08 880	0,22 335 0,07 1005	0,20 370 0,06 1150	0,16 460 0,05 1150	0,13 565				260 310	0,45	16	
807 PL3 807 PL4	0,05	0,06 735 0,025 1150	0,05 880 0,023 1150	0,033 1150 0,021 1150	0,019 1150	0,016 1150	0,015 1150	0,013 1150	0,012 1150	0,010 1150	0,008 1150	310 360	0,30	16
805 PL3	0,04	0,10 350	0,08 440	0,07 505	0,06 585	0,05 705	0,033 1065				285	0,25	16	

Available standard facewidth's: 260 - 275 - 310 - 360 - 410 - 460 - 510 - 560 - 610 - 660 - 710 - 760 - 810 - 860 mm

When an electro-mechanical brake is fitted, the minimum facewidth is increased by 75 mm

The total weight of a Drummotor grows approx. 1,8 kg per 100 mm

Maximum beltpull: 1150 N (Imax on request or on data plate)

Available torque: (Beltpull N x drum diameter m) / 2 Nm

# Dimensions mild steel

## TM 113B25

TM 113B25, mild steel Drummotor with polyamide junctionbox

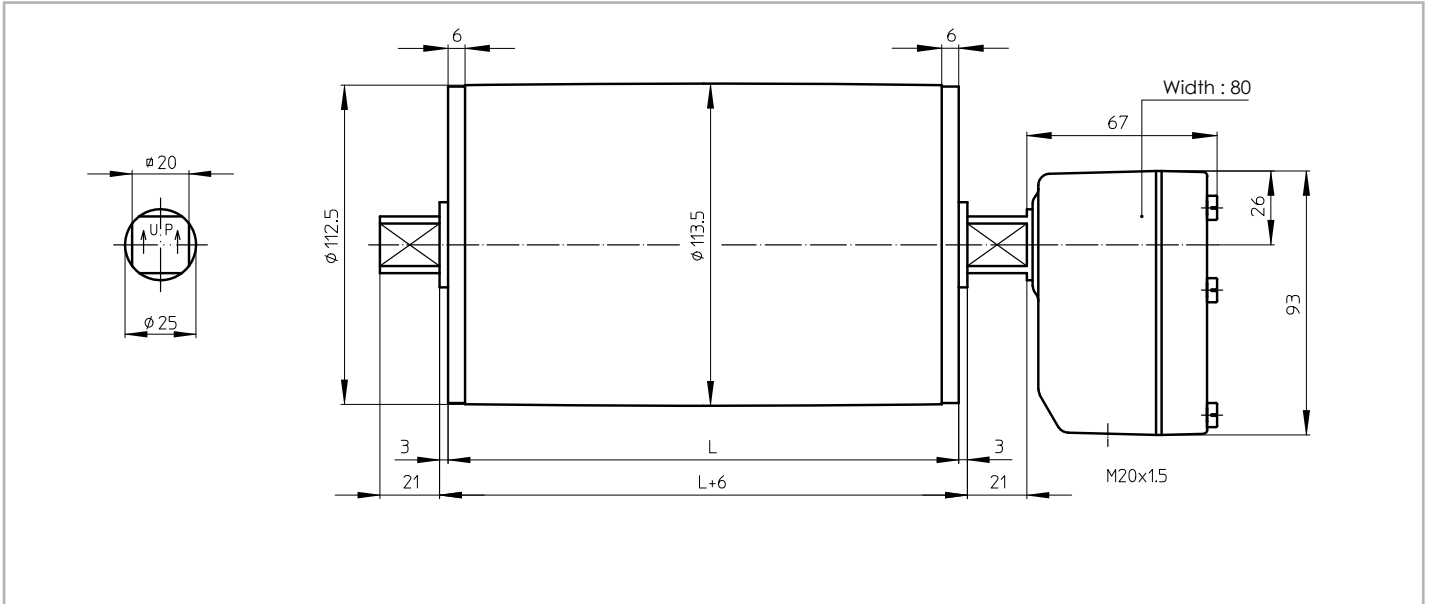

## KT 113B25

KT 113B25, mild steel Taildrum

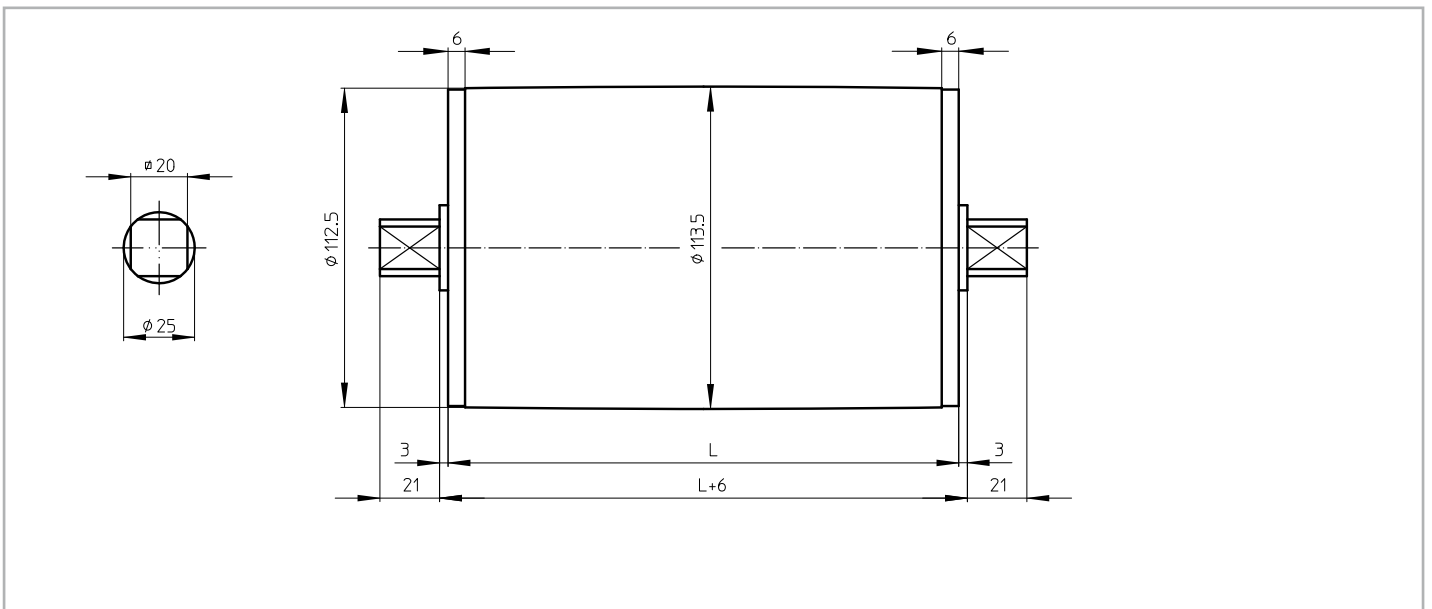



## Dimensions stainless steel

### TM 113B25 CR

TM 113B25 CR, stainless steel Drummotor with polyamide junctionbox and CR sealing

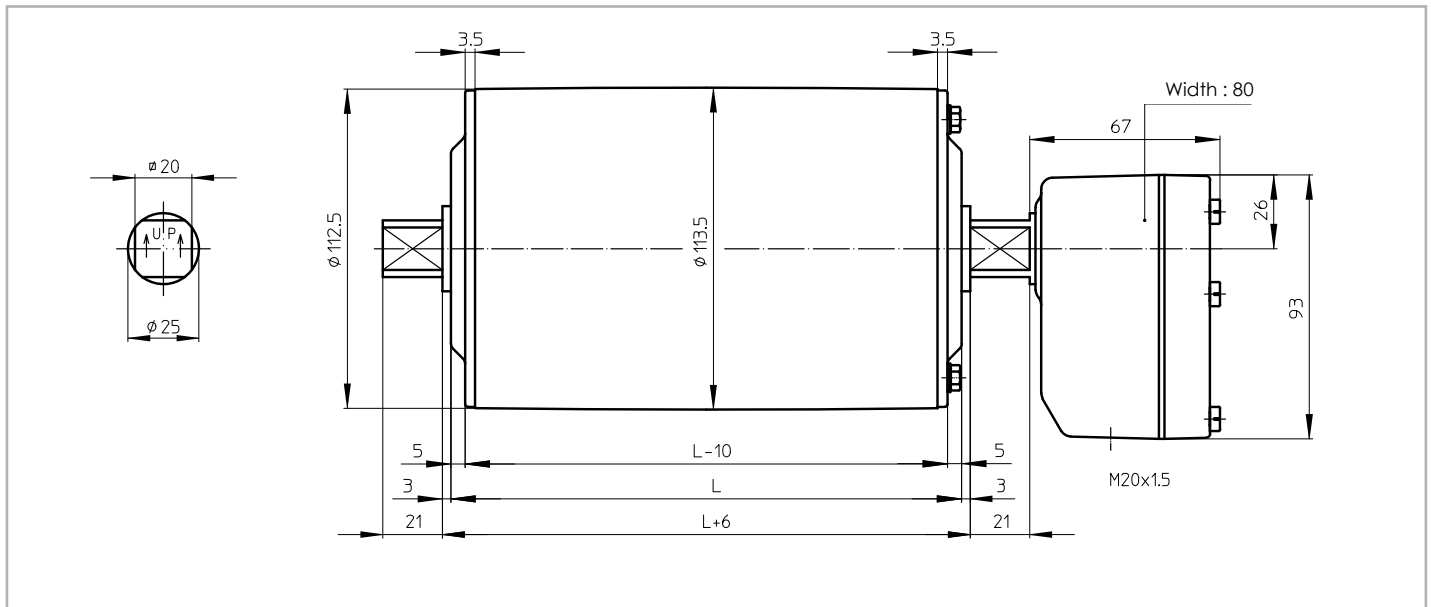

### KT 113B25 CR

KT 113B25 CR, stainless steel Taildrum with CR sealing

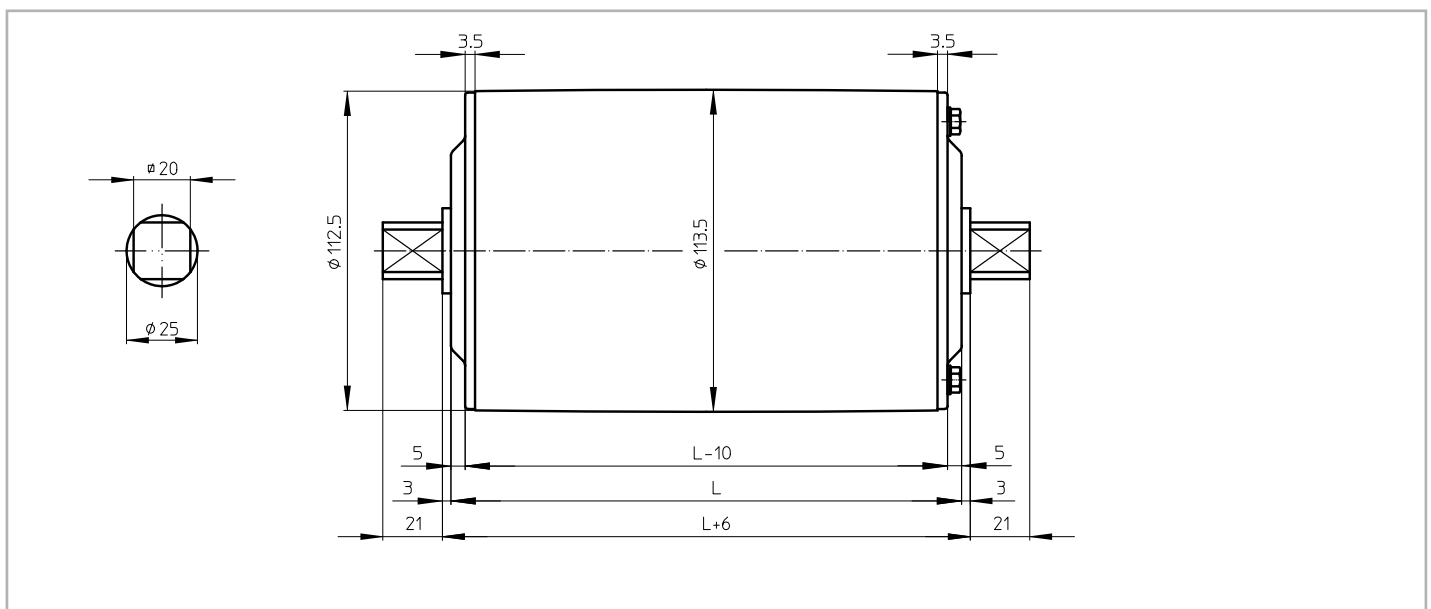

# Dimensions bracket / cable exit

## AB 20

AB 20, cast iron or stainless steel bracket  
Weight: 0,6 kg per pair

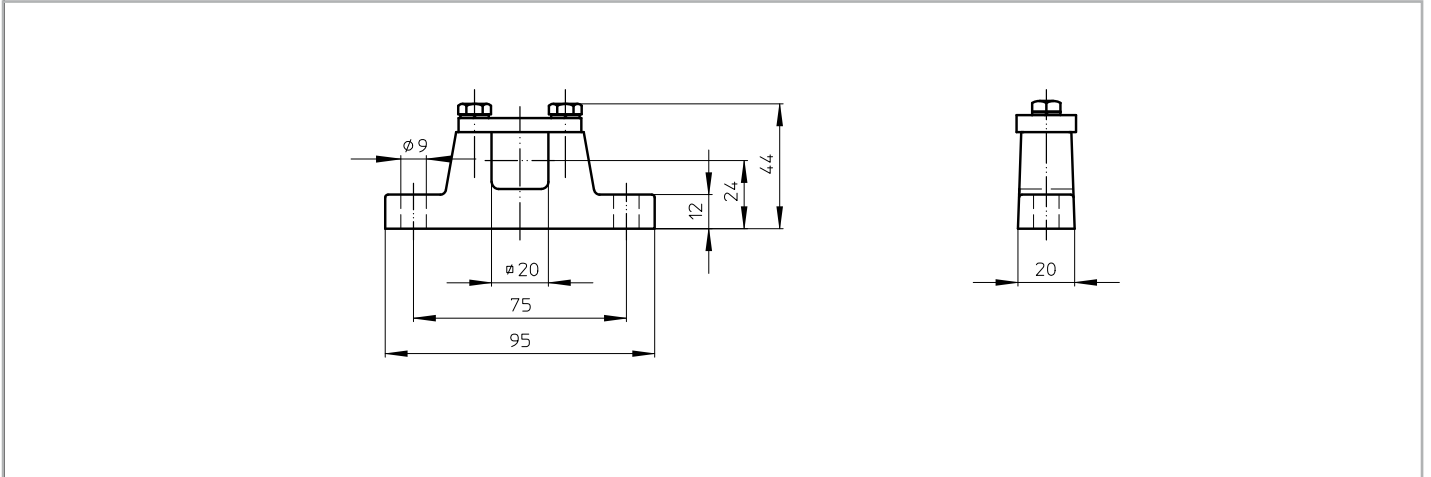

Standard design of a TM 113B25 is with a polyamide junctionbox. For stainless steel design, this can be either a polyamide or stainless steel junctionbox.

On request a Drummotor can be fitted with a cable. In this case it is important to know the available voltage (preferably 1 voltage), the length of the cable, whether the cable is shielded or not and the type of cable exit. An overview of available cable exits is shown below.

### Option 1

Straight cable exit with cable gland

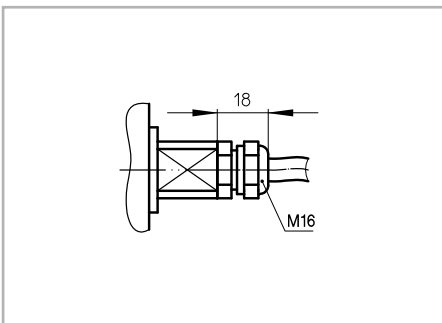

### Option 3

Elbow cable exit with cable gland  
(minimum facewidth increases with 25 mm)

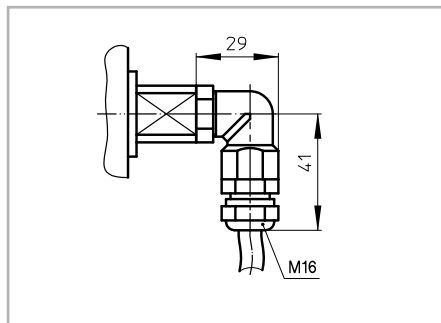

### Option 4

Open cable exit (minimum facewidth increases with 25 mm)

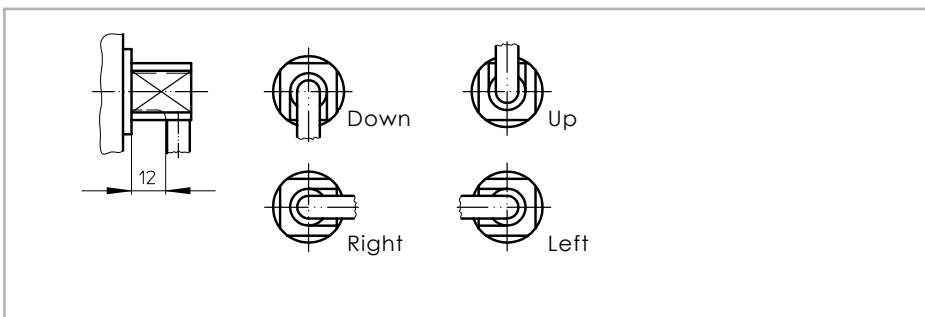





TM 113B25 Z

Legenda

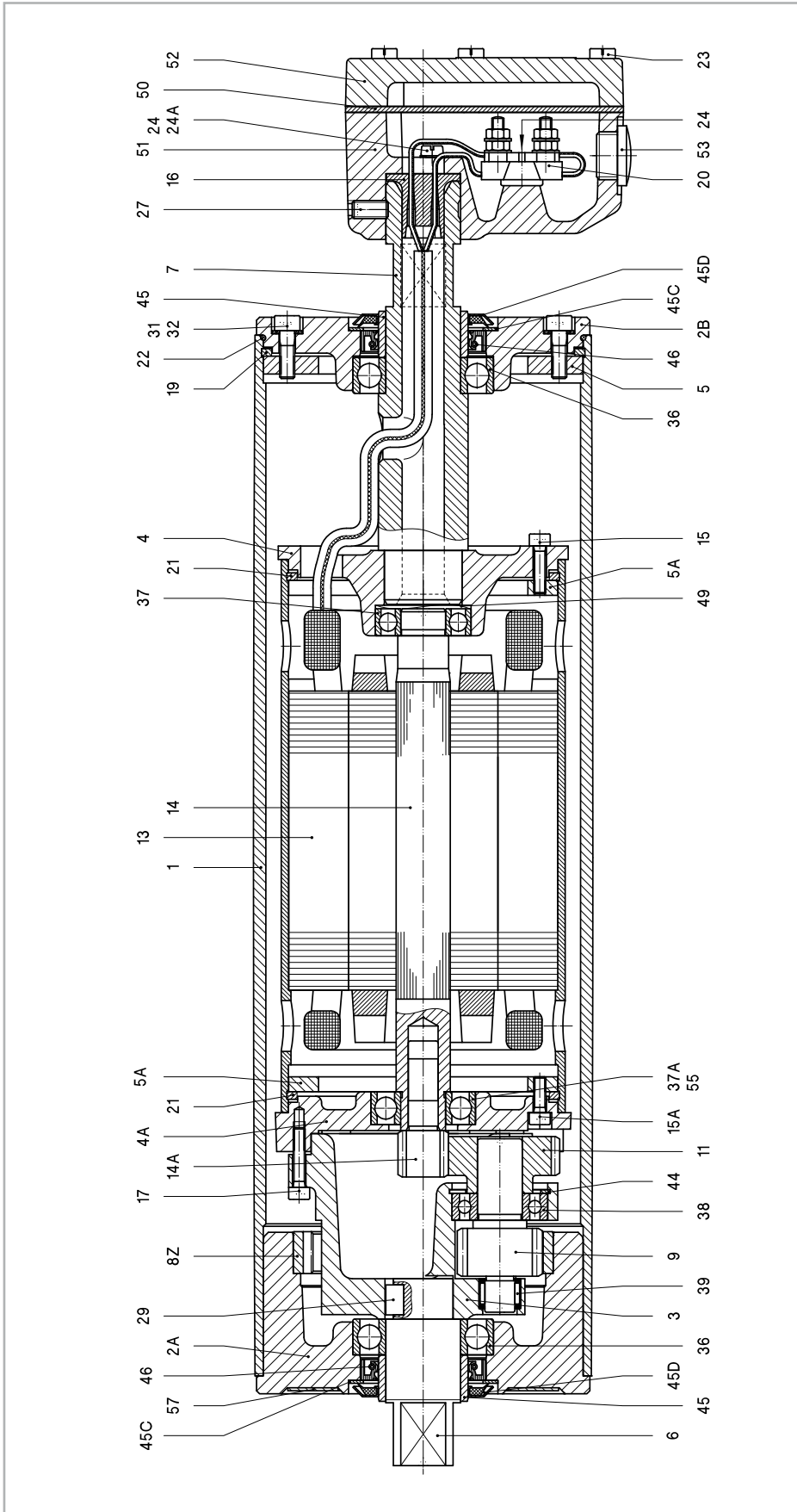

1	Shell	8Z	Internal gear	19	Springring	32	Washer	46	Oilseal
2A	Endflange	9	Pinion	20	Terminalboard	36	Ballbearing	49	Wave washer
2B	Endflange	11	Gear	21	Springring	37	Ballbearing	50	Seal
3	Gearhousing	13	Stator	22	O-ring	37A	Ballbearing	51	Junctionbox
4	Motorflange	14	Rotor	23	Cyl. head screw	38	Ballbearing	52	Junctionbox cover
4A	Motorflange	14A	Insert pinion	24	Cyl. head screw	39	Needlebearing	53	Stopping plug
5	Mountingring	15	Int. hex screw	24A	Toothed lock washer	44	Circlip	55	Ballbearing incl. backstop
5A	Mountingring	15A	Int. hex screw	27	Setscrew	45	Bearing race	57	Dataplate
6	Shaftend	16	Cable passage	29	Key	45C	Shim plated		
7	Hollow shaft	17	Int. hex screw	31	Int. hex screw	45D	Gammaring		

# Cross sectional / parts description

TM 113B25 PL2

Legenda

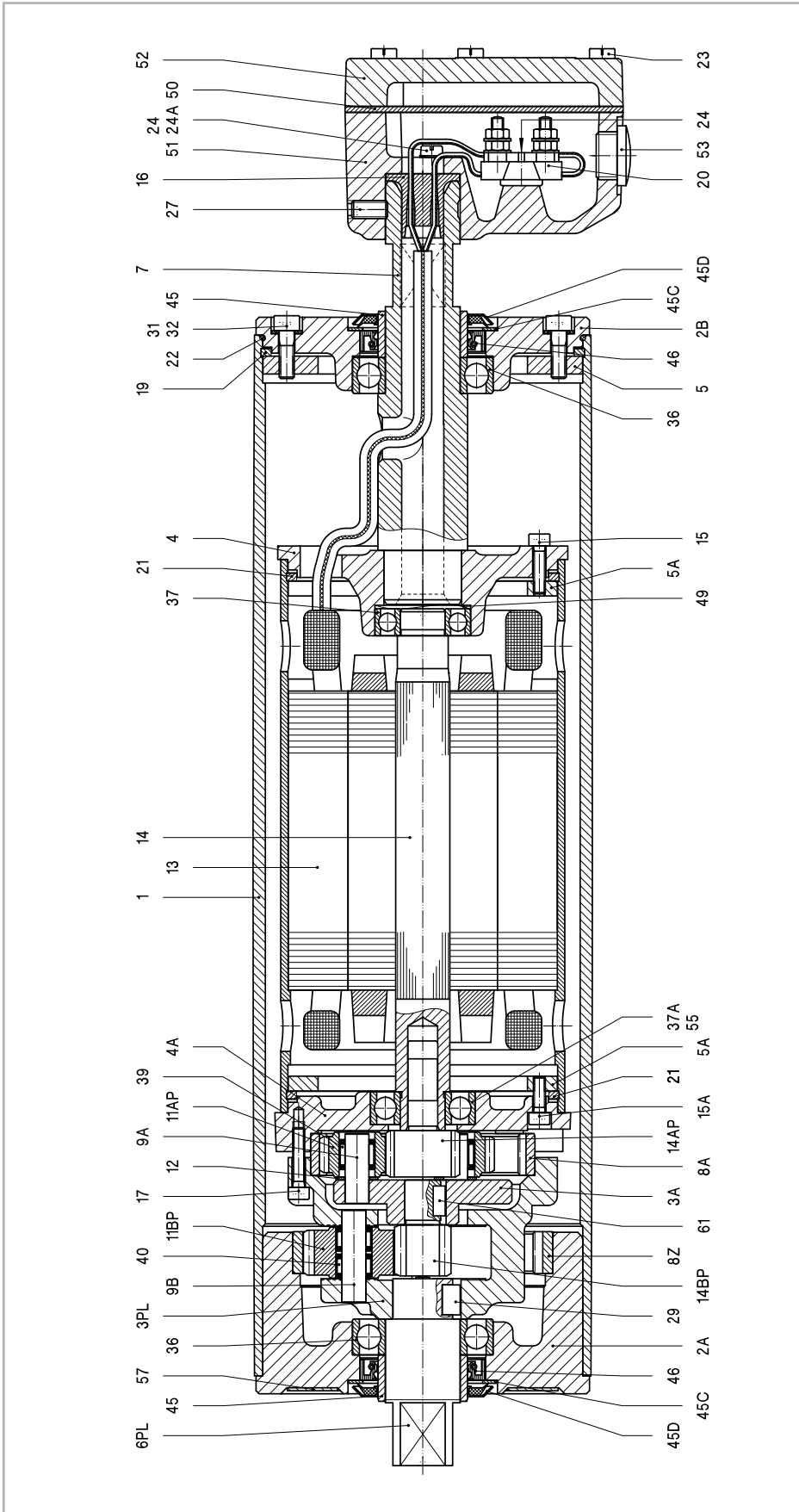

1	Shell	15	Int. hex screw	27	Setscrew	45D	Gammaring
2A	Endflange	15A	Int. hex screw	29	Key	46	Oilseal
2B	Endflange	16	Cable passage	31	Int. hex screw	49	Wave washer
3A	Planetary carrier	17	Int. hex screw	32	Washer	50	Seal
3PL	Planetary housing	19	Springring	36	Ballbearing	51	Junctionbox
4	Motorflange	20	Terminalboard	37	Ballbearing	52	Junctionbox cover
4A	Motorflange	21	Springring	37A	Ballbearing	53	Stopping plug
5	Mountingring	22	O-ring	39	Needlebearing	55	Ballbearing incl. backstop
5A	Mountingring	23	Cyl. head screw	40	Needlebearing	57	Dataplate
6PL	Shaftend	24	Cyl. head screw	45	Bearing race	61	Key
7	Hollow shaft	24A	Toothed lock washer	45C	Shim plated		
		8Z	Internal gear				
		8A	Internal gear				
		9A	Cylindrical pin				
		9B	Cylindrical pin				
		11AP	Planetary gear				
		11BP	Planetary gear				
		12	Shim				
		13	Stator				
		14	Rotor				
		14AP	Insert pinion				
		14BP	Sunwheel				
		17					
		18					
		19					
		20					
		21					
		22					
		23					
		24					
		24A					
		29					
		30					
		31					
		32					
		33					
		34					
		35					
		36					
		37					
		37A					
		38					
		39					
		40					
		41					
		42					
		43					
		44					
		45					
		46					
		47					
		48					
		49					
		50					
		51					
		52					
		53					
		54					
		55					
		56					
		57					
		58					
		59					
		60					
		61					



# Cross sectional / parts description

KT 113B25

Legenda

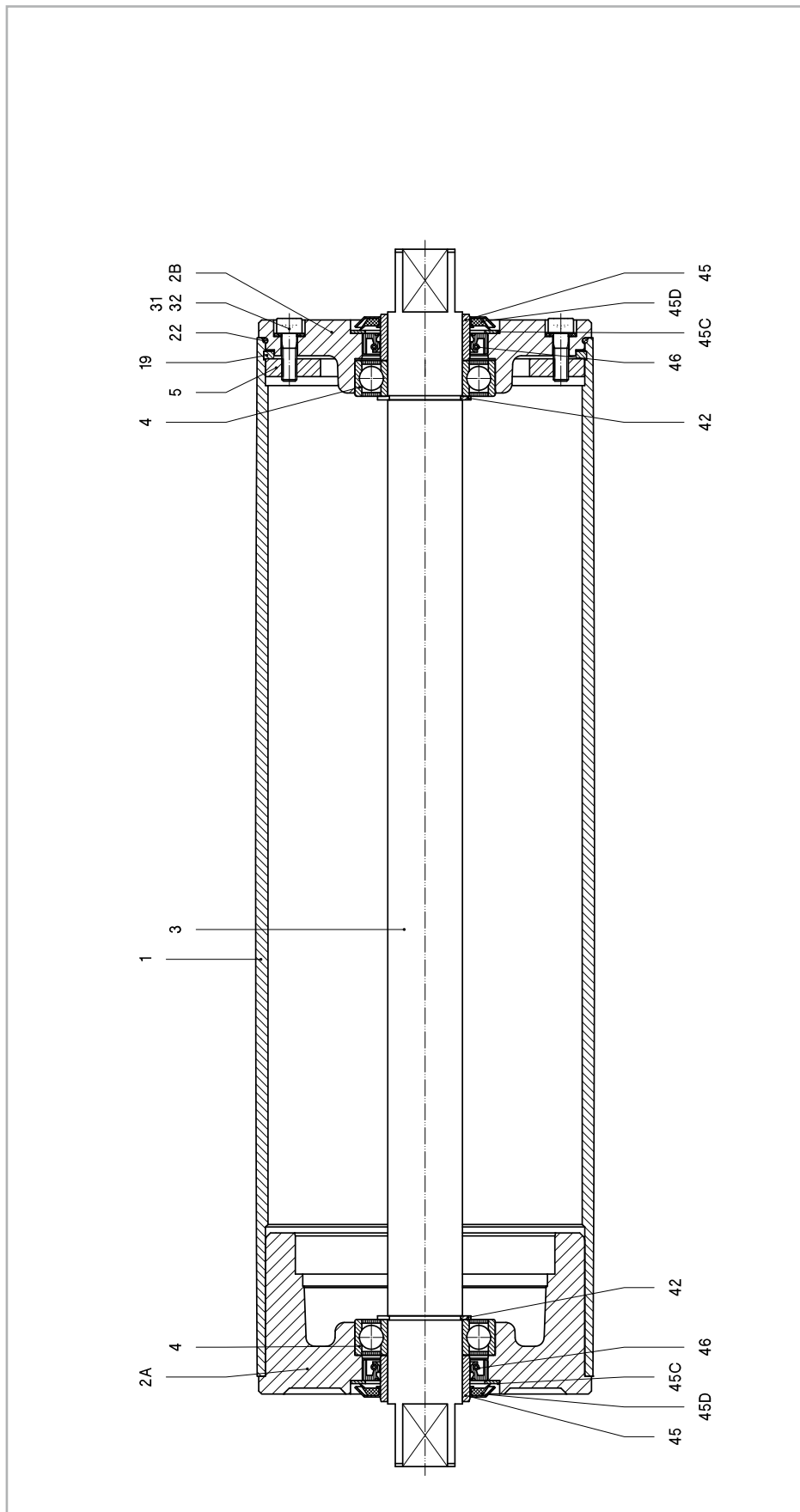

1	Shell	31	Int. hex screw
2A	Endflange	32	Washer
2B	Endflange	42	Circlip
3	Shaft	45	Bearing race
4	Ballbearing	45C	Shim plated
5	Mountingring	45D	Gammaring
19	Springring	46	O-liseal
22	O-ring		

## Material

The external parts of the Drummotor are made from mild steel and cast iron. Depending on the application it is also possible to manufacture in stainless steel (complete or part). You can choose between stainless steel 304 (general food industry) and stainless steel 316 (salt water applications).

## Backstop - Brake

If an inclined belt conveyor is stopped fully loaded, it could run backwards.

To prevent this we can install a backstop. One of the bearings in the Drummotor is replaced by a one way bearing. The way this bearing is installed determines the direction of rotation of the drum. TBRH indicates a cw rotation and TBLH ccw.

In situations where a Drummotor needs to be able to drive in both directions it is not possible to use a backstop. In this case we use a brake. When an declined belt or a horizontal belt needs to be stopped quickly to pick or place items a brake is the best solution.

## Inclined position

Sometimes a Drummotor needs to be installed on an inclined or even vertical position. This is possible, but we need to make adjustments to the oil level in the drum as the oil will flow to the lower side of the Drummotor causing the top bearing to run without lubrication. To prevent problems we will need to know the installation angle so we can fill the drum with extra oil and fit a double sealed bearing on the upper side.

## Thermal protection

A Van der Graaf Drummotor can be fitted with thermal protection. This consists of either a thermistor (PTC) or bi-metal (klixon). We install these on each phase of the electric motor.

## Encoder - Sensor bearing

In certain applications it is required to measure the speed or position of a conveyor belt. For this type of application we can install an encoder or sensor bearing to accurately measure rotational speed of the Drummotor.

The accuracy needed will determine the type of encoder or sensor used.

## Lagging

The power produced by the Drummotor has to be transferred to the belt and lagging is used to give more friction between the Drummotor and the conveyor belt. Van der Graaf can fit your Drummotor with different kinds of lagging.

There is a difference between cold and hot vulcanised lagging. Cold vulcanised means the lagging is glued to the Drummotor usually in sheet form and the join 'welded' together. Hot vulcanising is a process where the shell is wrapped around with thin layers of rubber. The shell with the rubber is then baked in an autoclave fusing the layers together creating a seamless finish.

It is possible to cut grooves (e.g chevron or diamond) in the lagging.

## Sprockets

Do you wish to use a Drummotor to drive modular belts? Van der Graaf can help you! Fitting sprockets suitable for various types of modular belts is a simple solution. The Drummotor is manufactured with a cylindrical shell and machined with a patented 'keying' system. The sprockets are simply 'slid' on and locked securely into position.

## Sealings for mild steel Drummotors and Taildrums

RB sealing - IP 66



This is Van der Graaf's standard sealing. This type of sealing will work in most conditions.

RBS sealing - IP 66



This sealing is specifically designed for those applications where high water pressure is used for cleaning.

HD sealing - IP 66



This sealing is designed for abrasive applications, like sand, gravel and soil.

## Sealings for stainless steel Drummotors and Taildrums

CR sealing - IP 66



This is our standard sealing for stainless steel Drummotors, a very effective, multi labyrinth sealing.

UW sealing - IP 68



This sealing is suitable for under water applications. The maximum depth is approx 2,5 m.

# Options

Specification	Standard	Optional
<b>Construction</b>		
Shafts and bolts	Mild steel	Stainless steel
Endflanges	Cast iron	Stainless steel
Shell	Mild steel	Stainless steel
Junctionbox	Polyamide	Cast iron or stainless steel
Cable		Shielded or non-shielded
Sealing mild steel	RB	RBS, HD
Sealing stainless steel	CR	UW
<b>Shell</b>		
Crowned	•	
Cylindrical		•
Balanced		•
Lagging, cold vulcanised		•
Lagging, hot vulcanised		•
Lagging, FDA approved		•
Fitted with grooves, patterns		•
Sprockets		•
<b>Electro motor</b>		
Three-phase asynchronous	•	
Power supply	230/400 V - 50 Hz	Other voltages and frequencies on request
Single phase (230 V - 50 Hz)		•
Insulation class	F	H
Thermal protection		Bi-metal or thermistor
Run by frequency inverter	•	
<b>Other options</b>		
Food grade oil		•
Backstop, mechanical		•
Brake, electro mechanical		•
Clutch brake, electro mechanical		•
Inclined or vertical position		•
Other facewidth's		•
Different shaft designs		•
Encoder or sensor bearing in drum motor		Sensor bearing
Encoder or sensor bearing in tail drum		•
<b>Certificates</b>		
CE	•	
UL		•
CSA		•
ATEX zone 22, dust		•
UW Under water application (IP68)		•



## Product range

### Our products, an overview

Drum motor type	TM 100B25	TM 113B25	TM 127.25	TM 138.25	TM 160.25	TM 160.30	TM 215.30	TM 215.40
Drum diameter (mm)	100	113	127	138	160	160	215	215
Shaft diameter (mm)	25	25	25	25	25	30	30	40
Power (kW)	0.05-0.37	0.04-0.55	0.10-1.1	0.10-1.1	0.10-0.75	0.10-2.2	0.10-2.2	0.37-5.5
Speed (m/s)	0.007-3.60	0.008-4.40	0.008-2.60	0.009-2.80	0.13-3.30	0.06-4.00	0.08-5.30	0.12-4.70

Drum motor type	TM 215B50	TM 273.40	TM 315.40	TM 315.50	TM 400A50	TM 400.60	TM 500A60	TM 500A75
Drum diameter (mm)	215	273	315	315	400	400	500	500
Shaft diameter (mm)	50	40	40	50	50	60	60	75
Power (kW)	1.5-4.0	0.37-5.5	0.37-5.5	1.1-11	1.1-11	1.5-22	1.5-22	11-30
Speed (m/s)	0.18-0.31	0.17-5.00	0.18-5.20	0.16-4.40	0.20-4.80	0.20-4.60	0.25-4.70	0.80-3.20

Drum motor type	TM 620A75	TM 630A100	TM 800A100	TM 800A130
Drum diameter (mm)	620	630	800	800
Shaft diameter (mm)	75	100	100	130
Power (kW)	11-30	22-55	22-55	55-132
Speed (m/s)	1.00-3.90	1.00-4.00	1.25-5.10	1.60-4.50

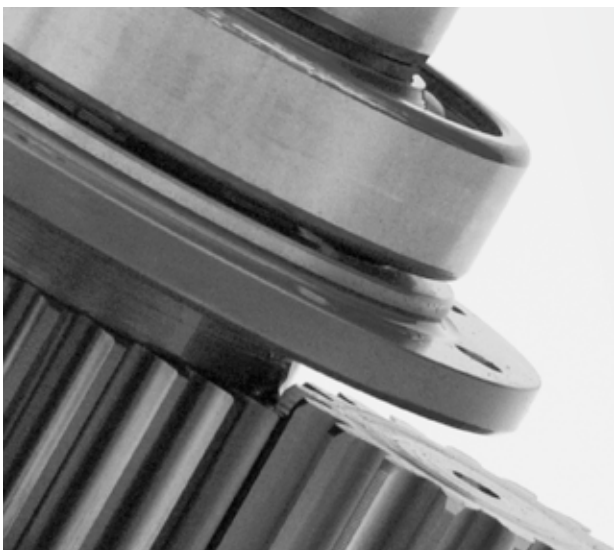

#### Design benefits

- Robust, industrial design
- Fully enclosed
- Oil filled
- Well-sized gears and bearings

#### Installation advantages

- Easy to install
- Compact and reliable
- Easy to clean
- Virtually maintenance free
- Low Life Cycle Costs





# Van der Graaf

## Power Transmission Equipment

### Contact us

#### Netherlands

Van der Graaf B.V.  
De Weijert 14  
P.O. Box 3  
8325 ZG Vollenhove  
Tel: 00 31 527 241441  
Fax: 00 31 527 241488  
E-mail: [info@vandergraafpte.nl](mailto:info@vandergraafpte.nl)  
[www.vandergraafpte.nl](http://www.vandergraafpte.nl)



#### Canada

Van der Graaf Inc.  
2 Van der Graaf Court  
Brampton  
Ontario L6T 5R6  
Tel: 00 1 905 793 8100  
Fax: 00 1 905 793 812  
E-mail: [info@vandergraaf.com](mailto:info@vandergraaf.com)  
[www.vandergraaf.com](http://www.vandergraaf.com)



#### Great Britain

Van der Graaf U.K. Ltd.  
Unit 23, The Metro Centre  
Welbeck Way Woodston  
Peterborough PE2 7UH  
Tel: 00 44 1733 391777  
Fax: 00 44 1733 391044  
E-mail: [sales@vandergraaf.co.uk](mailto:sales@vandergraaf.co.uk)  
[www.drummy.com](http://www.drummy.com)



#### USA

Van der Graaf Corp.  
51515 Celeste  
Shelby Township  
48315 Michigan  
Tel: 00 1 866 595 3292  
Fax: 00 1 888 326 0089



#### Germany

Van der Graaf GmbH  
Rheiner Straße 24 B  
48432 Rheine-Mesum  
Tel: 00 49 5975 306210  
Fax: 00 49 5975 3062120  
E-mail: [info@vandergraaf.de](mailto:info@vandergraaf.de)  
[www.vandergraaf.de](http://www.vandergraaf.de)



#### Sweden

Van der Graaf Scandinavia AB  
Spingatan 2  
267 73 Billesholm  
Tel: 00 46 42 22 0802  
Fax: 00 46 42 22 0803  
E-mail: [info@vandergraaf.se](mailto:info@vandergraaf.se)  
[www.vandergraaf.se](http://www.vandergraaf.se)



#### Finland

Van der Graaf Scandinavia AB  
Tel: 00 358 400 419063  
E-mail: [info@vandergraaf.fi](mailto:info@vandergraaf.fi)  
[www.vandergraaf.fi](http://www.vandergraaf.fi)